

REV. NO		REV. HISTORY	LTR	ECO NO	DATE	APPR'L
DWG	PART					
00	00	INITIAL RELEASE	-	-	-	-

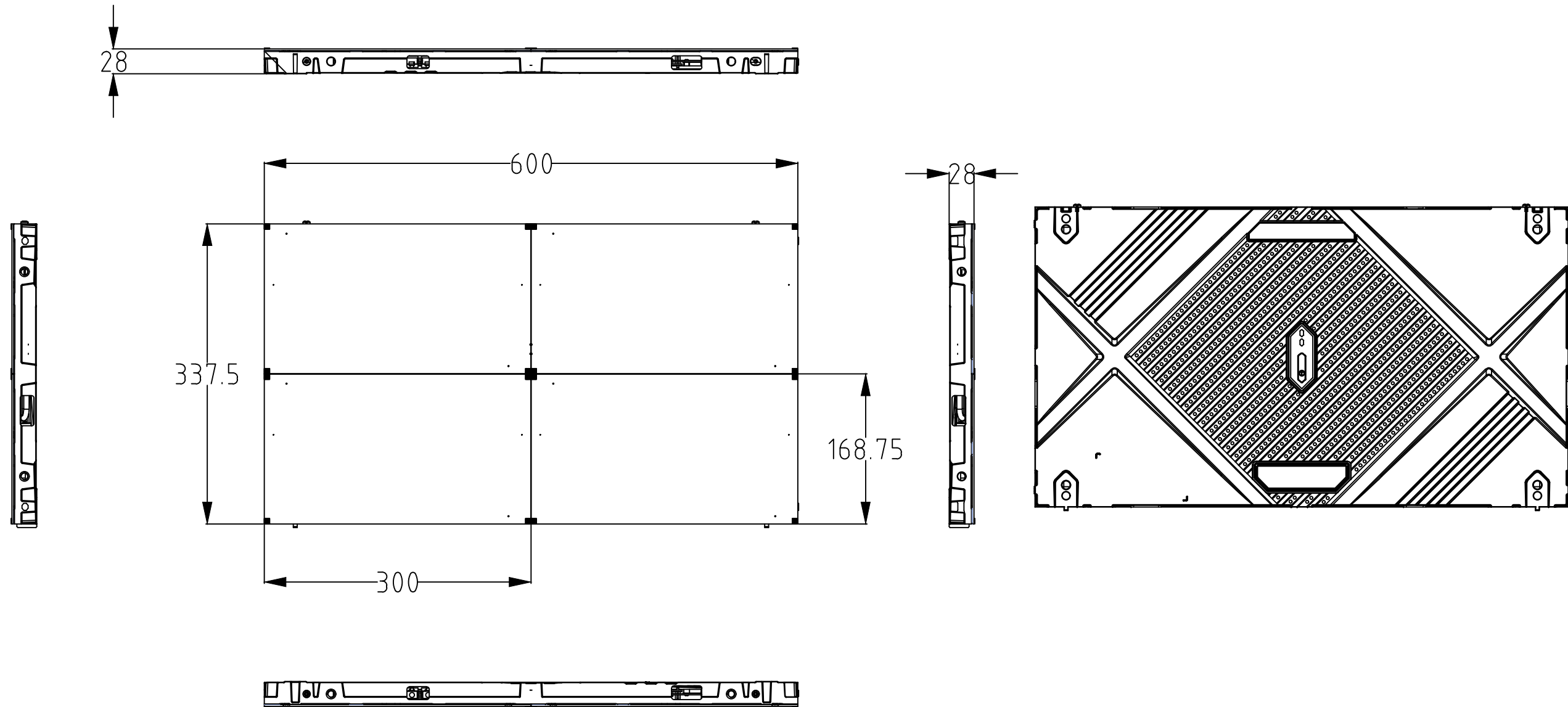

HIU0.9 / 1.2 / 1.5 / 1.8

DRAWN	PLANNED	CHECKED	APPROVED	UNLESS OTHERWISE SPECIFIED ALL DIMENSION ARE IN MILLIMETERS	ANGLE 3rd.	TITLE :	UNIT :
-	-	-	-		TOLERANCES ARE : LINEAR : X ± 0.2 .X ± 0.1 .XX ± 0.01 ANGLES : ± 0.1° RADH UNLESS NOTED : R 0.3		SCALE : 1/10
HYUNDAI IT CO., LTD.				MODEL NAME (CODE): -	CUSTOMER. HDIT	DWG REV : 00	DWG(PART) NO.
				FILE NAME : HYUNDAI_IT_2D_CAD_LAYOUT.DWG		SHT NO : 1/1	SIZE : A3

REV. NO		REV. HISTORY	LTR	ECO NO	DATE	APPR'L
DWG	PART					
00	00	INITIAL RELEASE	-	-	-	-

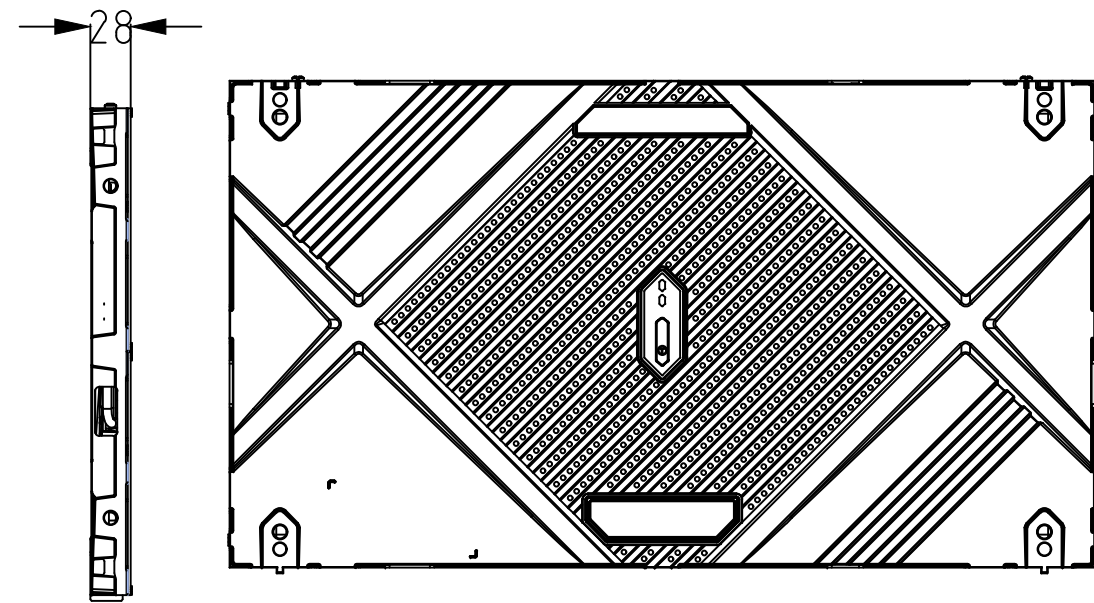
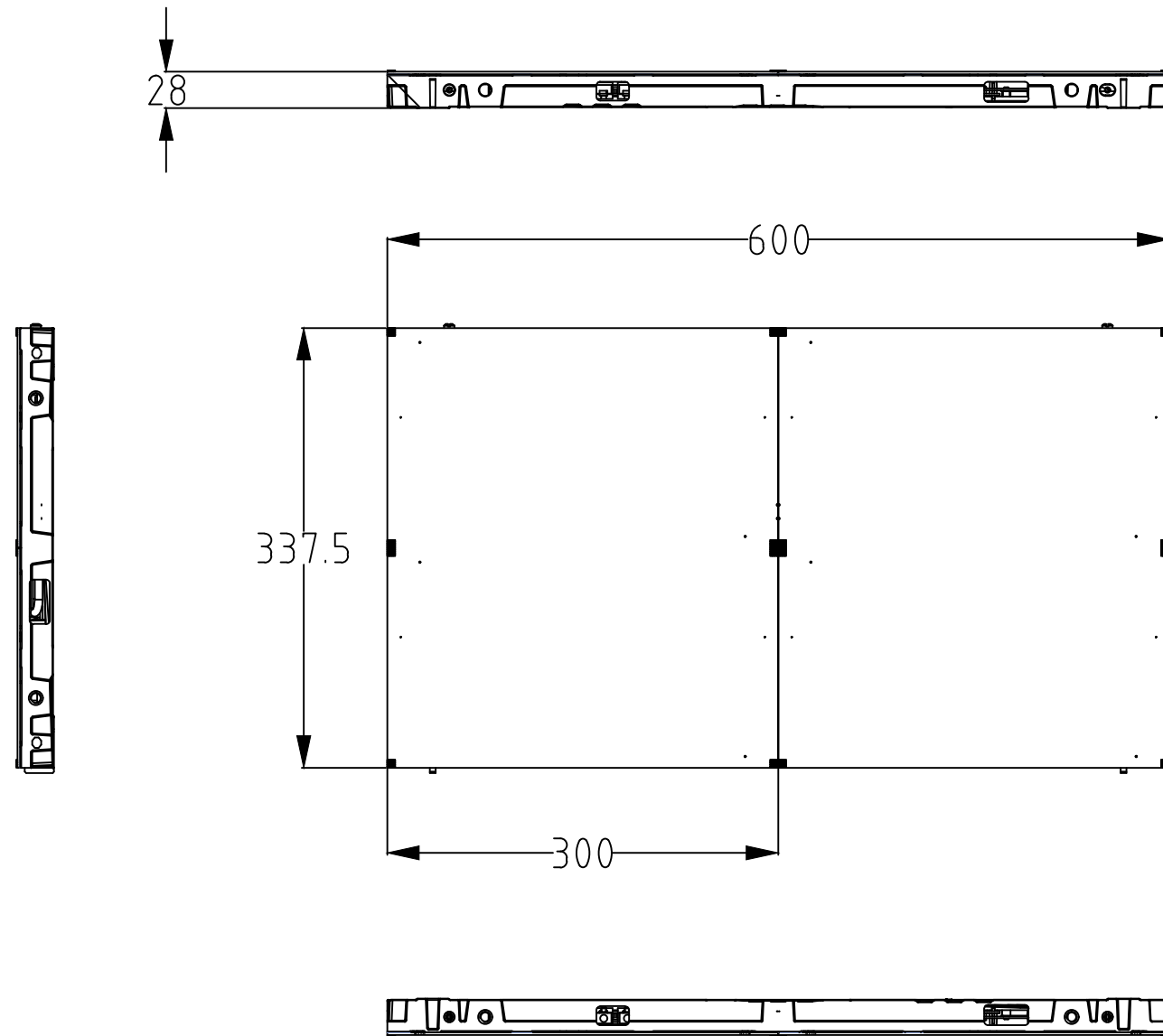

HIU2.5

DRAWN	PLANNED	CHECKED	APPROVED	UNLESS OTHERWISE SPECIFIED ALL DIMENSION ARE IN MILLIMETERS	ANGLE 3rd.	TITLE :	UNIT :
-	-	-	-	TOLERANCES ARE : LINEAR : X ± 0.2 .X ± 0.1 .XX ± 0.01 ANGLES : ± 0.1° RADH UNLESS NOTED : R 0.3	SCALE : 1/10	EXTERIOR VIEW	mm
HYUNDAI IT CO., LTD.				MODEL NAME (CODE): -	CUSTOMER. HDIT	DWG REV : 00	DWG(PART) NO.
				FILE NAME : HYUNDAI_IT_2D_CAD_LAYOUT.DWG	SHT NO : 1/1		SIZE : A3