

REV. NO		REV. HISTORY	LTR	ECO NO	DATE	APPR'L
DWG	PART					
00	00	INITIAL RELEASE	-	-	-	-

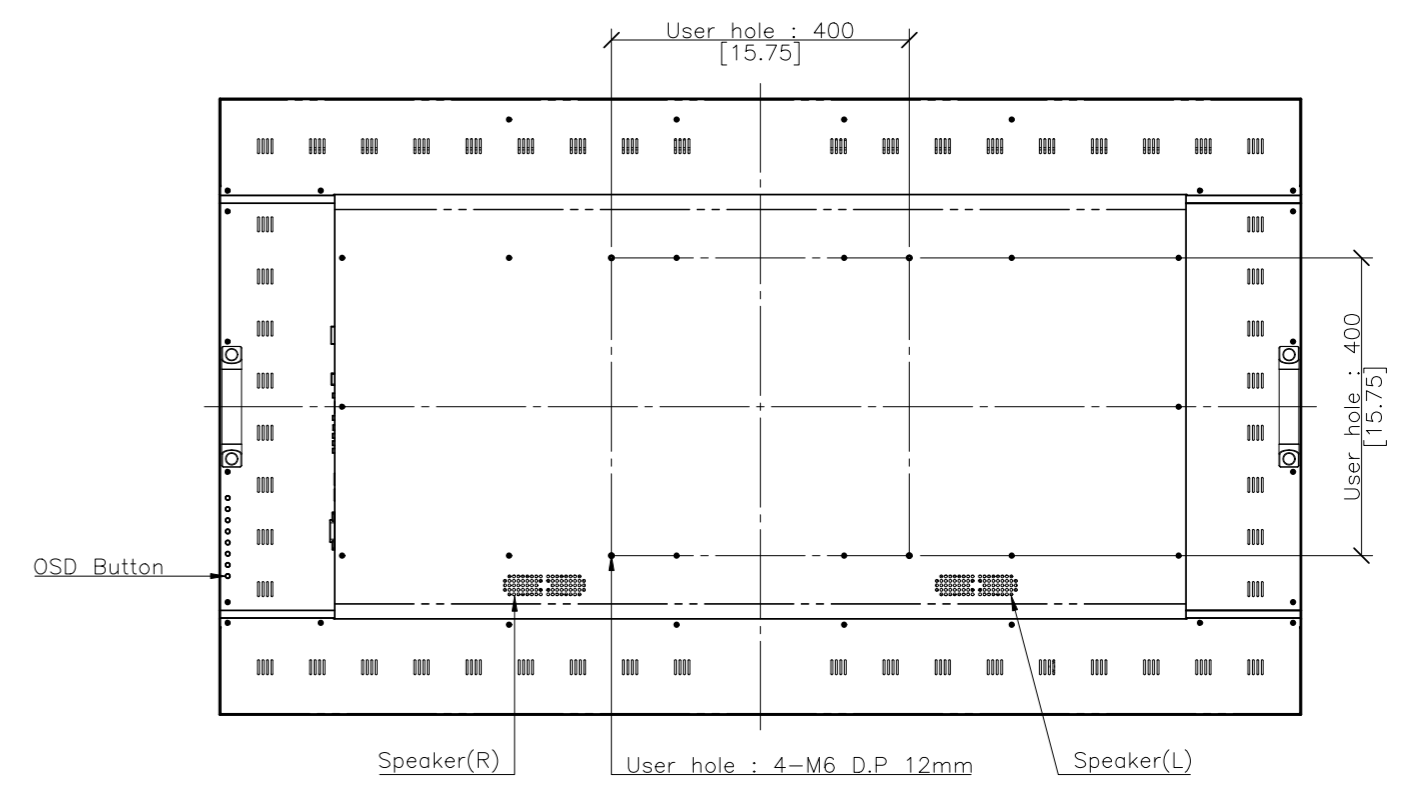
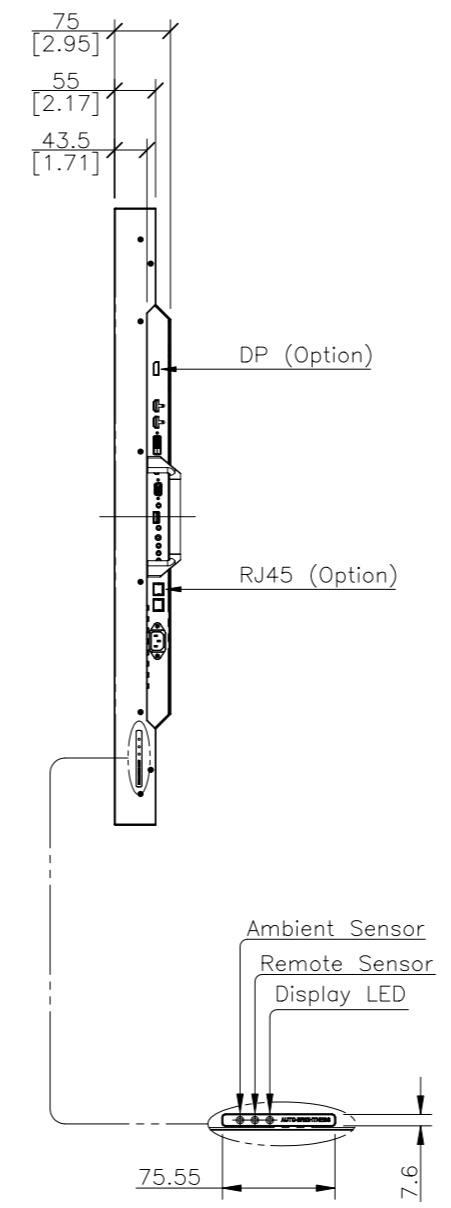
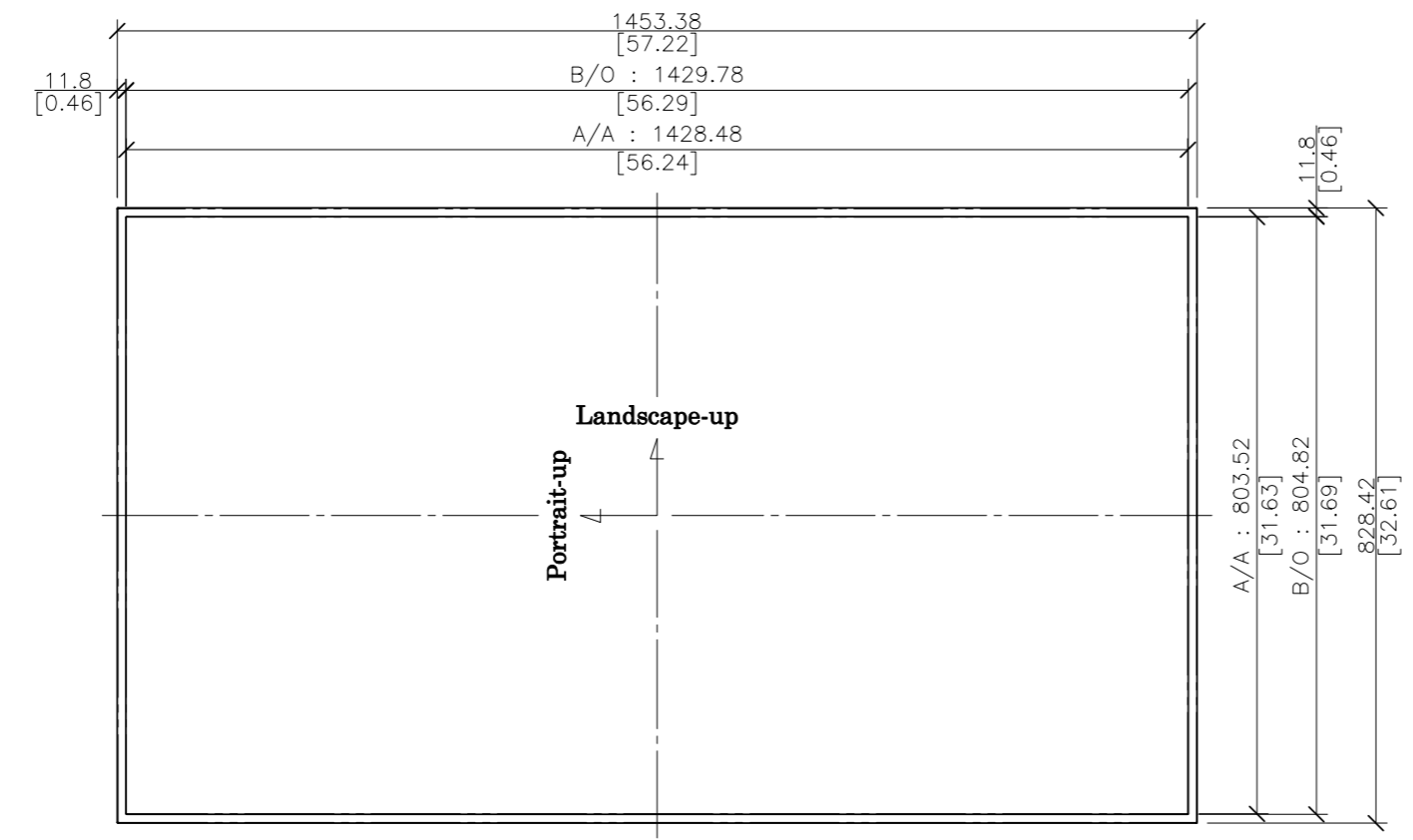
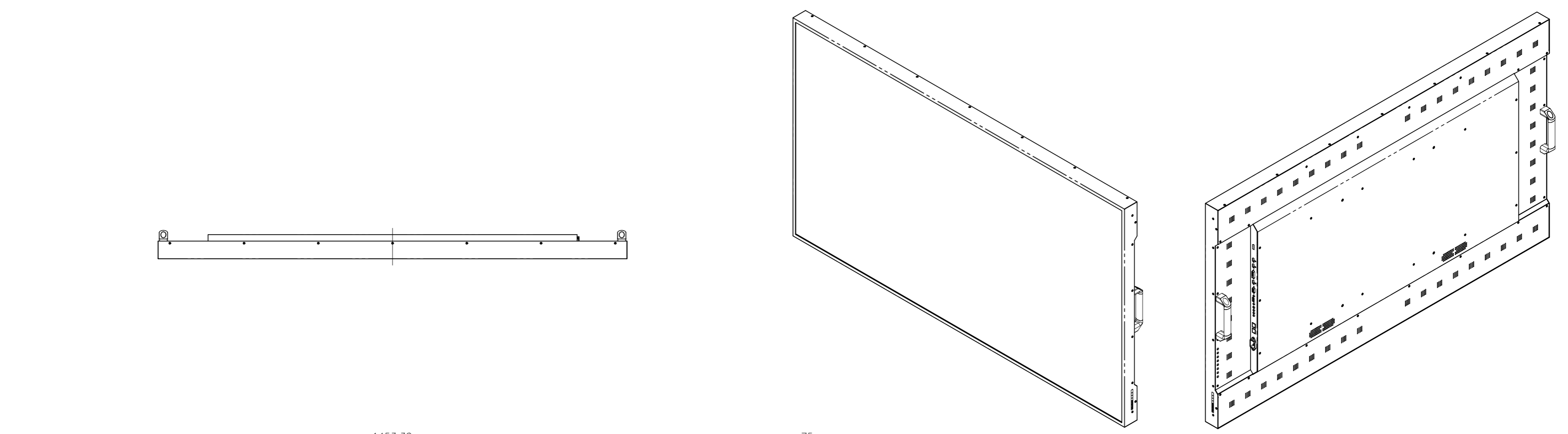

- NOTES**
- LCD Panel : 65"
  - Material : E.G.I
  - Color : Black

DRAWN	PLANNED	CHECKED	APPROVED	UNLESS OTHERWISE SPECIFIED ALL DIMENSION ARE IN MILLIMETERS	ANGLE 3rd.	TITLE	UNIT : mm
S.W.SEO	S.H.JANG	S.H.JANG	Y.T.KIM	TOLERANCES ARE : LINEAR : X ± 0.20 X ± 0.1 XX ± 0.01 ANGLE : ± 0.1° RADIH UNLESS NOTED : R 0.3	SCALE : 1/10	<b>M65ZMA EXTERIOR VIEW</b>	TYPE : PART
'22.06.10	'22.06.10	'22.06.10	'22.06.10	MODEL NAME (CODE): M65ZMA FILE NAME : LAYOUT_M65ZMA_220610.DWG	CUSTOMER: HDIT	DWG REV : 01 SHT NO : 1/1	SIZE : A2
<b>HYUNDAI IT CO., LTD.</b>						<b>DWG(PART) NO. M65ZMA_001</b>	

This drawing is the property of HYUNDAI IT CO.,LTD. and should not be disclosed to any third party without prior permission of HYUNDAI IT CO.,LTD.